

CBC-150 Series Clutch/Brake Controls

Installation and Operation Manual

P-239-21
819-0477

Introduction

The Warner Electric CBC-150 series is a family of clutch/brake controls which conveniently mount to the conduit box cover of the Electro Module line of electromagnetic clutches and brakes. The CBC-150 series controls are dual channel devices available in two models:

CBC-150-1 120 VAC input
 CBC-150-2 220/240 VAC input

These controls are designed for operation of all Warner Electric 90 VDC clutches and brakes. They should not, however, be used to directly power Warner Electric permanent magnet failsafe brakes as these products require an adjustable current or voltage supply for optimum release. These controls indicate when the output channels are energized with LEDs

Suppression circuitry insures fast coil decay for rapid cycle rates. Customer provided switching is accomplished on the AC input to the control.



⚠ WARNING Failure to follow these instructions may result in product damage, equipment damage, and serious or fatal injury to personnel.

Reorder Information

Model	Part Number
CBC-150-1	6004-448-001
CBC-150-2	6004-448-002
Conduit	5370-101-042

Specifications

Input

CBC-150-1: 120 VAC, 50/60 Hz, 1 phase, 200 VA max.
 CBC-150-2: 220/240 VAC, 50/60 Hz, 1 phase, 200 VA max.

Output

CBC-150-1: 90 VDC full-wave rectified nominal,
 Dual channel, 0.8A max. per channel.
 CBC-150-2: 90 VDC half-wave rectified nominal,
 Dual channel, 0.8A max. per channel.

Fusing (external to control, supplied by customer)

CBC-150-1: 2 amp, 125 V fast-blo
 CBC-150-2: 2 amp, 250 V fast-blo

Switching (Supplied by customer on AC input)

- Electromechanical (SPDT) (or Two SPST)
 - CBC-150-1: Rated 120 VAC, 1 amp minimum
 - CBC-150-2: Rated 240 VAC, 1 amp minimum
- Solid State (maximum leakage current < 2ma)
 - CBC-150-1: Rated 140 VAC, 2 amp minimum
 - CBC-150-2: Rated 280 VAC, 2 amp minimum

Ambient Temperature

-20° to +122°F (-29° to 50°C)

Cycle Rate

In most applications, the maximum cycle rate is limited by the clutch and/or brake capability rather than by the control. To determine specific capabilities, consult the Application Engineering section of Warner Electric's Catalogs. The following table lists those clutch/brake models whose maximum cycle rate may be limited by this control.

Models Limited by Control	Maximum Cycle Rate (cycles/min)
PB/PC-500	250
SF-500, EP-500, PB-650, EB-650	220
SF-650, EC-650, EM-210	175
PB/PC-825, EB-825	130
SF-825, EP-825, PC-1000, EB-1000	100
SF-825 brg., EC-825, EC-1000	95
SF-1000, EP-1000, PB/PC-1225	70
SF-1225, PB/PC-1525, EB-1225, AT-205	50
SF-1525, EP-1525, EC-1225	40
SF-1525HT	20

⚠ WARNING To avoid injury (or even death), always make certain all power is off before attempting to install this control or any electrical equipment.

Please refer to the Connection diagram when following these instructions.

1. Clutch/Brake Wiring
 - a. BRAKE (RED LED):
Connect the red wire to one of the brake leads; connect the red/white stripe wire to the other lead wire of the brake (or clutch).
 - b. CLUTCH (GREEN LED):
Connect the blue wire to one of the clutch leads; connect the blue/white stripe wire to the other lead wire of the clutch (or brake).
2. AC Input Wiring
 - a. BRAKE (RED LED):
Connect the black/red stripe wire to the hot side of the AC power source through the switch and fuse as indicated.
 - b. CLUTCH (GREEN LED):
Connect the black/blue stripe wire to the hot side of the AC power source through the switch and fuse as indicated.
 - c. Connect the white wire to the neutral side (other hot side for the CBC-150-2) of the AC power.
3. Secure the control to the conduit box with the (4) 10-32 Type F screws furnished.

⚠ CAUTION This is a floating type power supply and is not referenced to AC ground. Under no circumstances should any of the output wire leads be connected to earth or chassis ground as the unit will be destroyed.

Connection

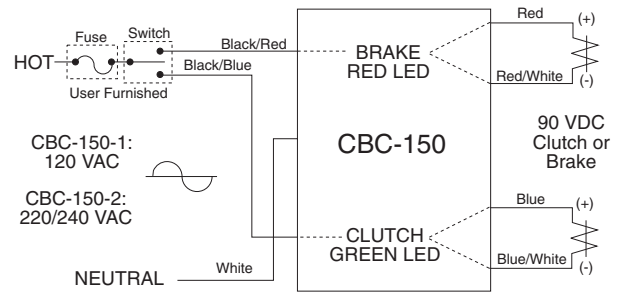

⚠ CAUTION Do not commonize any output wiring.

Dimensions

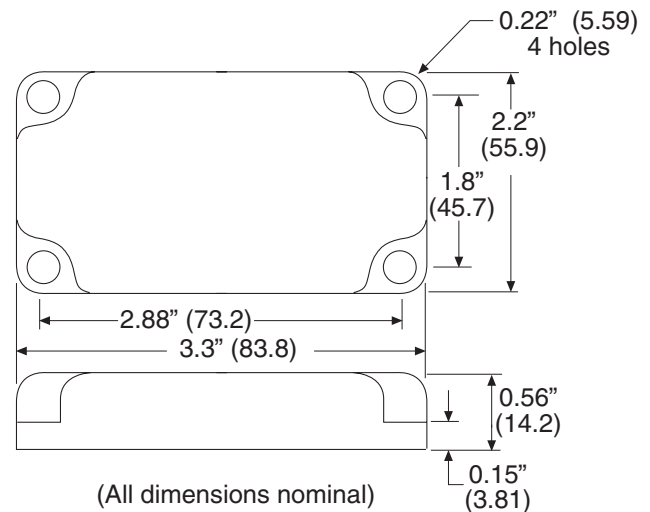



DECLARATION OF CONFORMITY

DECLARACION DE CONFORMIDAD

WE: **WARNER ELECTRIC**
31 Industrial Park Road
New Hartford, CT 06057

Nosotros: **WARNER ELECTRIC**
31 Industrial Park Road
New Hartford, CT 06057

declare under our sole responsibility that the products of the family

declaramos bajo nuestra propia responsabilidad que los productos de la familia

CBC 150-1
CBC 150-2

CBC 150-1
CBC 150-2

are exclusively designed for incorporation in another machine. The operation of the product is submitted to the conformity of the complete equipment, following the provisions of the directive **89/392/EEC**.

son diseñados exclusivamente para incorporarse en otra maquina. El funcionamiento de este producto esta sujeto al cumplimiento de todo el equipo usado en la maquina, con los lineamientos de la norma **89/392/EEC**.

The conformity of the above specified products with the provisions of the Directive **72/23/EEC** is supported by the full respect of the standards **EN 61010-1**.

El cumplimiento de los lineamientos de la norma **72/23/EEC** con los productos mencionados anteriormente, se basa y respeta los estandares **EN 61010-1**.

If the mounting and connecting instructions of the installation manual have been respected, this product will be conforming to the standards **EN50081-1** and **EN50082-1** relating to the EMC directive **89/336/EEC**.

Si las instrucciones de montaje e instalación electrica del instructivo son respetadas, este producto cumplirá con los estandares **EN50081-1** y **EN50082-1** que se relacionan con la norma **89/336/EEC**.

South Beloit, IL 61080
VP and General Manager: M. T.

South Beloit, IL 61080
VP and General Manager: M. T.



⚠ WARNING To avoid injury, always make certain all power is off before attempting to install or repair this control.



⚠ ADVERTENCIA: Para evitar cualquier daño personal, antes de intentar instalar o reparar este control, siempre asegurese que todas las fuentes de poder esten apagadas.

DO NOT TOUCH THE BOARD IF POWER IS APPLIED.

NO TOQUE EL CIRCUITO ELECTRICO SI LA FUENTE DE PODER ESTA ENCEDIDA.

Mounting and Connecting Instructions

related to the EMC-directive 89/336/EEC

For Clutch and Brake Control

1. The control must be mounted in a closed metal cabinet.
2. The power connection between control and clutch/brake must be MADE using shield cable.
3. The control connection must utilize shielded cables.
4. The shield of the cables must be grounded at both ends.
5. Power connections and control connection must be placed in separate canals.

INSTRUCCIONES DE MONTAJE Y CONEXIONES ELECTRICAS

en relación a la norma de EMC 89/336/EEC

PARA CONTROLES DE CLUTCHES Y FRENOS

1. El control debe de instalarse adentro de una caja metalica.
2. Las conexiones electricas entre el control y el cluch/freno DEBEN hacerse con cable blindado.
3. Las conexiones de bajo voltaje en el control deben utilizar cables blindados.
4. El blindaje de los cables debe de aterrizarse en ambos lados.
5. Las conexiones entre la fuente de poder, y las conexiones de bajo voltaje deben de hacerse en diferentes cables.

KONFORMITÄTSERKLÄRUNG

Wir: **WARNER ELECTRIC**
31 Industrial Park Road
New Hartford, CT 06057

erklären in alleiniger Verantwortung, daß die Produkte der Familie

CBC 150-1
CBC 150-2

ausschließlich zum Einbau in eine andere Maschine bestimmt sind. Die Inbetriebnahme ist solange untersagt, bis die Konformität des Endproduktes mit der Richtlinie **89/392/EWG** gegeben ist.

Die Übereinstimmung des bezeichneten Produktes mit den Vorschriften der Richtlinie **72/23/EWG** wird nachgewiesen durch die Einhaltung der Normen **EN 61010-1**.

Sofern die Montage-Anweisungen der Bedienungsanleitung eingehalten wurden, ist dieses Produkt knoform zu **EN50081-1** und **EN50082-1** und die EMV somit gewährleistet - Richtlinie **89/336/EWG**.

South Beloit, IL 61080
VP and General Manager: M. T.



⚠ WARUNG: Vor Einbau oder Wartung des Gerätes unbedingt die Stromversorgung unterbrechen um Verletzungen zu vermeiden.

KARTE BEI EINGESCHALTETER STROMVERSORGUNG NICHT BERÜHREN.

MONTAGE UND KABELVERBINDUNGEN ANWEISUNGEN

bezogen zu den EMW Richtlinie 89/336/EWG

FÜR STEURGERÄTE KUPPLUNGEN UND BREMSEN

1. Das Gerät muß in einem geschlossenen metallschrank eingebaut werden.
2. Leistungsverbindungen Steuergeräte/Kupplungen - Bremsen mit abgeschim Kabel durchfubren.
3. Steuerleitungen, Ein-und Ausgänge mittels abgeschimten Kabeln durchfuhren.
4. Abschirmung an beiden Enden des Kabels erden.
5. Leistungs-und Steuerverbindungen in separate Kabelkanäle durchziehen.

DÉCLARATION DE CONFORMITÉ

Nous: **WARNER ELECTRIC**
31 Industrial Park Road
New Hartford, CT 06057

déclarons sous notre seule responsabilité que les produits de la famille

CBC 150-1
CBC 150-2

sont uniquement destinés à l'intégration dans une machine. La mise en service de ces produits est subséquente à l'homologation de l'ensemble de l'équipement, conformément à la directive **89/392/CEE**.

La conformité des produits spécifiés ci-dessus avec les exigences de la directive **72/23/CEE** est supportée par le respect des normes **EN 61010-1**.

Si les instructions de montage et de câblage du manuel sont respectées, ce produit est conforme aux normes **EN50081-1** et **EN50082-1** directive **89/336/CEE** relative à la CEM.

South Beloit, IL 61080

VP and General Manager: M. T.



⚠ ADVERTISSEMENT: Afin d'éviter des blessures, s'assurer que toute puissance soit coupée avant installation ou intervention sur ces équipements.

NE PAS TOUCHER LE CIRCUIT ÉLECTRONIQUE, SI LA PUISSANCE EST APPLIQUÉE.

INSTRUCTIONS D'INSTALLATION ET DE CABLAGE

relatives à la CEM, directive 89/336/CEE

DES CONTROLES POUR EMBRAYAGES ET FREINS

1. L' appareil doit être monté dans une armoire métallique close.
2. Liasion de puissance entre contrôle et embrayage/frein par câble blindé.
3. Raccordements de consigne, entrées et sorties par câbles blindés.
4. Les blindages sont reliés à la terre aux deux extrémités du câble.
5. Les câbles de commande et les câbles de puissance ne seront pas placés dans le même caniveau.

Warranty

Warner Electric LLC warrants that it will repair or replace (whichever it deems advisable) any product manufactured and sold by it which proves to be defective in material or workmanship within a period of one (1) year from the date of original purchase for consumer, commercial or industrial use.

This warranty extends only to the original purchaser and is not transferable or assignable without Warner Electric LLC's prior consent.

Warranty service can be obtained in the U.S.A. by returning any defective product, transportation charges prepaid, to the appropriate Warner Electric LLC factory. Additional warranty information may be obtained by writing the Customer Satisfaction Department, Warner Electric LLC, 449 Gardner Street, South Beloit, Illinois 61080, or by calling 815-389-3771.

A purchase receipt or other proof of original purchase will be required before warranty service is rendered. If found defective under the terms of this warranty, repair or replacement will be made, without charge, together with a refund for transportation costs. If found not to be defective, you will be notified and, with your consent, the item will be repaired or replaced and returned to you at your expense.

This warranty covers normal use and does not cover damage or defect which results from alteration, accident, neglect, or improper installation, operation, or maintenance.

Some states do not allow limitation on how long an implied warranty lasts, so the above limitation may not apply to you.

Warner Electric LLC's obligation under this warranty is limited to the repair or replacement of the defective product and in no event shall Warner Electric LLC be liable for consequential, indirect, or incidental damages of any kind incurred by reason of the manufacture, sale or use of any defective product. Warner Electric LLC neither assumes nor authorizes any other person to give any other warranty or to assume any other obligation or liability on its behalf.

WITH RESPECT TO CONSUMER USE OF THE PRODUCT, ANY IMPLIED WARRANTIES WHICH THE CONSUMER MAY HAVE ARE LIMITED IN DURATION TO ONE YEAR FROM THE DATE OF ORIGINAL CONSUMER PURCHASE. WITH RESPECT TO COMMERCIAL AND INDUSTRIAL USES OF THE PRODUCT, THE FOREGOING WARRANTY IS IN LIEU OF AND EXCLUDES ALL OTHER WARRANTIES, WHETHER EXPRESSED OR IMPLIED BY OPERATION OF LAW OR OTHERWISE, INCLUDING, BUT NOT LIMITED TO, ANY IMPLIED WARRANTIES OF MERCHANTABILITY OR FITNESS.

Some states do not allow the exclusion or limitation of incidental or consequential damages, so the above limitation or exclusion may not apply to you. This warranty gives you specific legal rights and you may also have other rights which vary from state to state.

Changes in Dimensions and Specifications

All dimensions and specifications shown in Warner Electric catalogs are subject to change without notice. Weights do not include weight of boxing for shipment. Certified prints will be furnished without charge on request to Warner Electric.



Warner Electric LLC
31 Industrial Park Road • New Harford, CT 06057
815-389-3771 • Fax: 815-389-2582
www.warnerelectric.com